

STAGEMAKER



INSTALLATION

MAINTENANCE

SPARE PARTS



Table of contents

	page	Up date ref
1 EC Declaration of conformity	1	9803
2 What not to do	2	9803
3 What to do	3	9803
4 Guarantee	4	9803
5 General		
5-1 Acceptance of the material	5	9803 A
5-2 Installation	5	9803 A
6 Description - technical characteristics		
6-1 Types of hoists	6.1	9807
6-2 Main sub-assemblies	6.1	9807
6-3 Hoist dimensions and weight	6.2	9807
6-4 Environmental data	6.2	9807
6-5 Operation of the hoist	6.2	9807
7 Brake/limiter assembly		
7-1 Operation	7	9803 C
7-2 Adjustment of the limiter	7	9803 C
7-3 Adjustment of the brake	7	9803 C
8 Lifting assembly		
8-1 Slack fall stop (in the chain bucket)	8.1	9807
8-2 Chain " <u>certificate</u> "	8.1	9807
8-3 Removal of the chain	8.2	9807
8-4 Replacement of the chain (1- fall & 2 - fall chain)	8.2	9807
8-5 Hook " <u>certificate</u> "	8.3	9807
8-6 Suspension hook	8.3	9807
8-7 Measurement of the wear on the hooks	8.3	9807
9 Electricity		
9-1 Generals	9.1	9807
9-2 Low voltage control	9.1/2/3/4	9807
9-3 Direct control	9.5	9807
10 Maintenance - replacement		
10-1 Maintenance table	10.1	9803 C
10-2 Lubricants	10.1	9803 C
10-3 Spare parts replacement table	10.2	9803 C
10-4 Screw tightening torques	10.2	9803 C
10-5 Discarding the hoist	10.2	9803 C
11 Troubleshooting	11	9803
12 Illustrated catalogue		
12-1 Casings	12.1	9807
12-2 Mechanism/Brake	12.2	9803 C
12-3 Lifting assembly	12.3	9807
12-4 Electric box	12.4	9803 C
12-5 Upper and Lower Limit Switch (OPTIONAL)	12.5	9803 C

1 - EC Declaration of conformity



As defined by the EC directive relating to machinery 98/37/EEC.

Annex II A

Herewith, we declare that the product:

Wire rope hoist	Belt hoist	Electric chain hoist	Manual chain hoist	Electric trolley	Manual winch
•	•	•	•	•	•
•	•	•	•	•	•
•	•	•	•	•	•
•	•	•	•	•	•
•	•	•	•	•	•
•	•	•	•	•	•
•	•	•	•	•	•
•	•	•	•	•	•
•	•	•	•	•	•
•	•	•	•	•	•
•	•	•	•	•	•
•	•	•	•	•	•
•	•	•	•	•	•
•	•	•	•	•	•
•	•	•	•	•	•
•	•	•	•	•	•
•	•	•	•	•	•
•	•	•	•	•	•
•	•	•	•	•	•
•	•	•	•	•	•

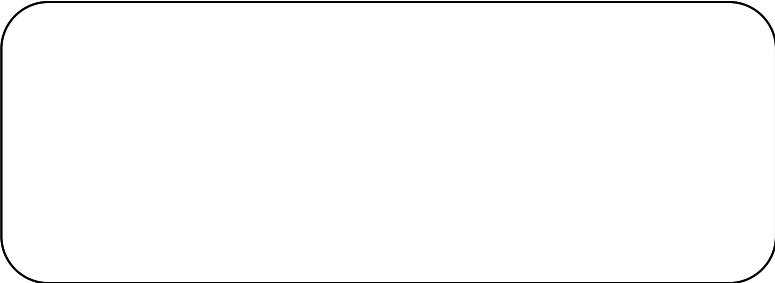

Complies with the following provisions applying to it:

- Machinery directive 98/37/EEC.
- Directive 73/23/CEE.
- "EMC" Directive 89/336/EEC

Applied harmonized standards, in particular:

- EN 60204-1,
- EN 292, parts 1 and 2 (safety of the machines).

National regulations, standards and specifications:

- order of June 9, 1993 / circular of September 22, 1993.
- decree no. 92-765, 92-766, 92-767, of July 29, 1992.
- DIN 15400; DIN 15401,

Quality system applied:

- EN29001/ISO9001

Technical standards and specifications complied with, in particular:

- FEM 9.511 "classification of the mechanisms".
- FEM 9.661 "dimensions and quality of the drive and cable lifting block elements for mass-produced lifting devices".
- EN 818 "chain quality, choice criteria and technical requirements".
- FEM 9.683 "choice of motors".
- FEM 9.755 "steps to be taken to determine the operating periods for mass-produced motorized lifting mechanisms (S.W.P.)".
- FEM 9.751 "Motorized lifting mechanism: safety"
- FEM 9.901 "bases of design for the mass-produced lifting devices for travelling cranes equipped with mass-produced lifting devices".

Bernard DELEFOSSE

2 - What not to do

Never move or lift the hoist by the electric cables.

Do not set down the hoist without having an adapted support, to avoid damaging the components on the underside (*electric cable, lifting chain, fixed point, PG cable gland, chain bucket...*).

Never modify the hoist unless the manufacturer has studied and authorized the modification.

Never modify the values and adjustments of the safety components, outside the limits provided for in the manual, or without the approval of the manufacturer.

Never try to repair or intervene on the hoist (*welding...*) without the authorization of the manufacturer or a trained maintenance agent.

Do not let an unqualified person use the hoist.

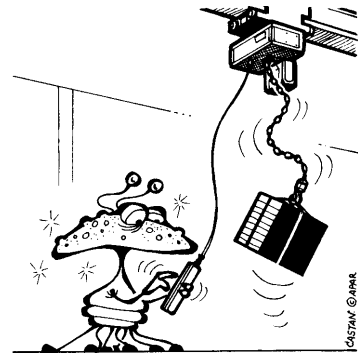

Do not allow unqualified person use the hoist.

Never lift more than the maximum working load indicated on the hoist. Shocks or accidental collision of the load with objects can cause excess loads.

Never remove the hook safety catches.

Never block, adjust or remove the limit switches or stops to go higher or lower moving distances.

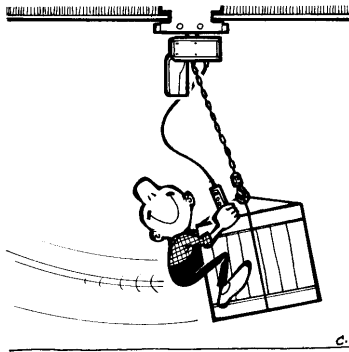

Never swing the load intentionally.

Never use the hoist to extract, loosen, or pull sideways.

Never use the hoist to transport people.

Do not touch the moving components.

Do not operate the hoist if your physical condition does not allow it.

Never use the hoist when in bad repair (*wear, deformation...*).

Never use suspect spare parts or parts whose origin is not known.

Never swing the load intentionally.

Do not subject the hoist to loading shocks.

Do not use the mechanical stops as a repetitive means of stopping.

Never use the lifting chain as a sling.

Never sling onto the hook jaw (as there is a risk of damage to the hook and of the load falling).

Never use a hook other than in the vertical position.

Never twist the load chains (*turning the hook block around...*).

Never distract the operator while the hoist is being operated.

Never leave a suspended load hanging.

Never use the hoist as grounding for welding.

Do not use the hoist for a purpose or in an area for which it is not intended.

Do not expose the hoist to an inappropriate atmosphere (*temperature, acidity... Refer to 6.7: Environmental data*).

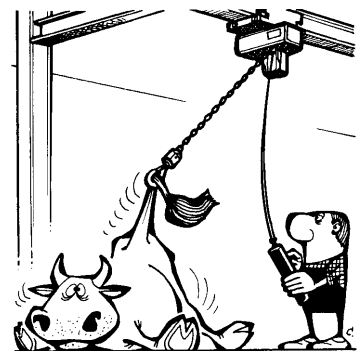

Never side pull the load.

Do not use the safety components as operation components.

Do not use the controls needlessly (avoid inching - stop-start operation of the buttons). This can cause overheating and even damage to the hoist.

Never angle pull the load, maximum angle 3 degrees.

Do not use the hoist with a power supply that is different to the one recommended (*undervoltage or overvoltage, absence of phase...*).

Never transport a load with people nearby. Do not move the hook, with or without a load, over personnel.

3 - What to do

Handle the hoist by its structure, or by the devices provided for this purpose, or in its original packing.

Store the hoist in its normal operating position (without load) away from aggressive atmospheres (*dust, humidity...*).

Make sure that the hoist is always clean and protected from corrosion (*lubrication...*).

The hoist should be installed by a competent.

Make sure that the hoist attaching structure is rigid.

Make sure that the safety rules are followed (*harness, clearance of work areas, posting up of instructions to be followed in the area...*).

The hoist should be maintained regularly, following the instructions in this manual.

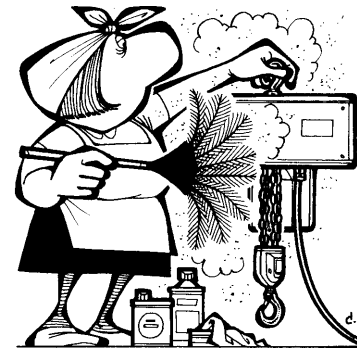

Make sure that the hoist is always clean.

Keep the moving components clean and oiled as indicated in this manual.

The components should only be replaced by original parts that are compatible with the type of hoist.

Make sure that the limit stops are in place.

Always be ready during operation to press the emergency stop button. This makes all functions inactive.

Before operation, check that the load is correctly fastened and installed on the hook. The hook safety catches should be closed correctly.

Make sure that the load is correctly balanced before moving it. Avoid lifting using only one point of the load. Use adequate accessories (*slings, lifting beam...*). Pay attention to the center of gravity of the load to be moved.

The elements used to hang the load should be free in relation to the load to be moved (*prefer a sling to a rigid beam*).

When moving the load, make sure that it is sufficiently raised and clear surrounding machines and other objects.

Make sure that the hoist is vertical to the load before hoisting.

If manually moving the hoist, push the load.

Use plastic stops, or better still, electric limit switches, to avoid repetitive stops on the stops.

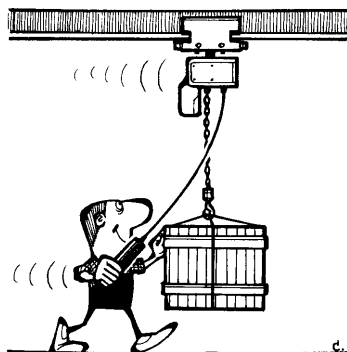

If manually moving the hoist, push the load.

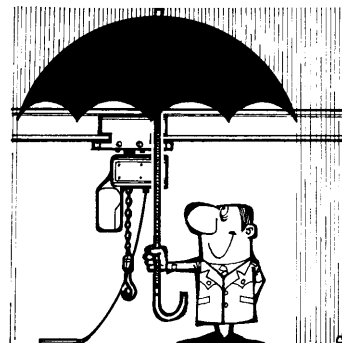

Material used outdoors should be protected as well as possible against bad weather conditions.

The prevention instructions to be carried out during the different operations should be well known.

Avoid rocking the load or the hook when using the traveling trolley or crane, by limiting the starting and braking jerks.

In the case of several speeds, do the starting and braking operations at low speed.

Use the material under normal working conditions (*ambient temperature, atmosphere...*).

Material used outdoors should be protected as well as possible against bad weather conditions.

The use of several machines to move a single load should be done by an experienced supervisor. All the necessary precautions should be taken to carefully ensure the distribution of the loads and to avoid overloading a single machine. The machines should be carefully checked before such an operation.

Notify the necessary people after a dangerous operation or if the hoist seems problematic (*abnormal noise, abnormal behavior...*).

Material used outdoors should be protected as well as possible against bad weather conditions. Hoist should be covered to avoid water going inside the chain bucket. A hole must be made to the chain bucket's bottom to let water to drain out.

4 - Guarantee

Our electric chain hoists are guaranteed **for two years** from the date of delivery.

If for a reason outside the control of the vendor, the delivery is delayed, the delay cannot exceed three months.

If the use (*installation*) of the hoist is delayed, the corresponding extension of the guarantee (a single extension limited to three months) must be requested, and written confirmation obtained.

The vendor undertakes to eliminate all operating errors originating from the concept, the execution, the components or the materials themselves.

The guarantee does not cover normal wear*, nor the failures resulting from lack of regular and periodic maintenance. It does not cover damage due to a lack of supervision, to false operation or to a bad utilization of the hoists, particularly due to overload conditions, slantwise drawing, undervoltage or overvoltage or a connection error.

The guarantee does not apply when there is disassembly, modification or replacement of parts (*mechanical or electrical*) by an unauthorized party or prior agreement with manufacturer.

The guarantee only applies for original, factory-installed spare parts, including the chain.

For the duration of the guarantee, the vendor undertakes to replace or repair, free of charge, the parts that are acknowledged to be damaged following examination by a qualified and authorized technical service.

The guarantee excludes any other services or indemnities. The repairs covered by the guarantee are carried out, as a rule, in the workshops of the vendor or authorized agent. When servicing of the equipment is done outside these workshops, the labor costs for disassembly or assembly of these parts are borne by the vendor when these are done exclusively by his staff or by an authorized agent. The replaced parts become the property of the vendor and must be returned to the vendor at his expense.

For components of a relative particular importance that are not manufactured by the vendor and which carry the brand name of specialized manufacturers, the manufacturer's guarantee (which can vary according to the manufacturer) is applicable.

* The guarantee does not apply for expendable parts defined by the manufacturer :

- Lifting chain
- Chain guide
- Rubber buffer
- Sprockets
- Chain bucket
- Hooks
- Friction and brake discs
- Control box cable

5 - General

5-1 Acceptance of the material

Visually inspect the packaging to ensure that it is intact.
If not, notify it as required.
Check that the hoist corresponds to your order.
For transport reasons the chain bucket is delivered disassembled.

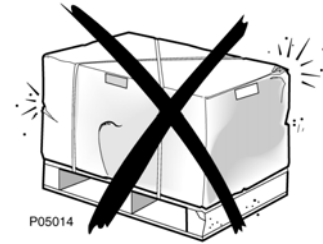

5-2 Installation

The service life of the hoist depends on the way it is installed.
The instructions in this manual must be followed carefully for the installation, use and maintenance of the hoist.
Any use contrary to our instructions can be dangerous. In this case, the manufacturer will not accept any responsibility.
Do not use the hoist until this manual has been fully read and assimilated.
Always keep this manual near the hoist, available to the operator and the person in charge of maintenance.
Make sure that the safety rules are followed (*harness, clearance of work areas, posting up of instructions to be followed in the area...*).

Carry out:

- The electrical connection (*refer to 9-4: Electrical connection*).
- Fitting of the chain bucket (*refer to 8.1: Chain bucket*).
- Check that the suspension hook is correctly positioned, depending on whether for 1 or 2 falls.

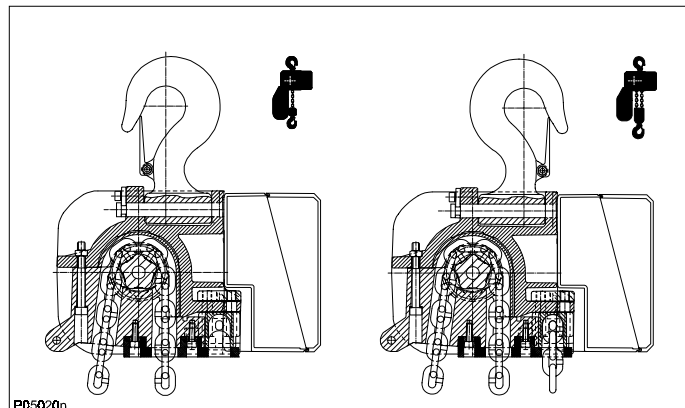

- Check that the tightening torques of the hook blocks, locking plates and chain guide conform to the torques indicated in this manual (*refer to 10.5: Screw tightening torques*).
- Check that the chain is not twisted.
- Check that the slack fall stop is correctly attached in the chain bucket and that the fixed point and the 2-fall chain are correctly held.
- Check that the rubber buffer is correctly fitted.
- Measure the dimension of the opening of the suspension hooks and the hook block. Note it for a follow-up.

Once these checks have been completed, proceed as follows (be ready to press the emergency stop button at all times).

- Oil and start to run in the chain by a few movements without load.
- Check, when not under load, that the movement of the hook corresponds to the direction of the arrows on the control box. If not, invert 2 supply phases.
- Check the operation of the limiter: operate the hoist, without a load, until it reaches the upper and lower hook positions and let the limiter slip for a maximum of 3 seconds. The chain should not move and the motor should continue to run.
- Check the operation of the brake: lift up a nominal load and then lower it.
- Check the operation and the adjustment of the limit switch.

Carry out dynamic tests with +10% of the nominal load and static tests with +50% of the nominal load on your installation equipped with our hoist.

IMPORTANT !

The slack fall stop is a safety component, not a functional one.
A correct length of chain is required to avoid using it.

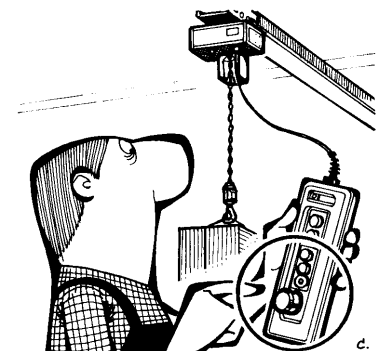

6 - Description - technical characteristics

6-1 Types of hoist

Type	Load kg	Load (T)	Speed m / min.	Speed ft / mn	Power mot. / kW	Brins falls	Chain d/t
SM10 1004 m1	1000	1	4	16	0,9	1	6,8 / 17,8
SM10 1008 m1	1000	1	8	32	1,75	1	„
SM10 2002 m1	2000	2	2	8	0,9	2	„
SM10 2004 m1	2000	2	4	16	1,75	2	„

6-2 Main sub-assemblies

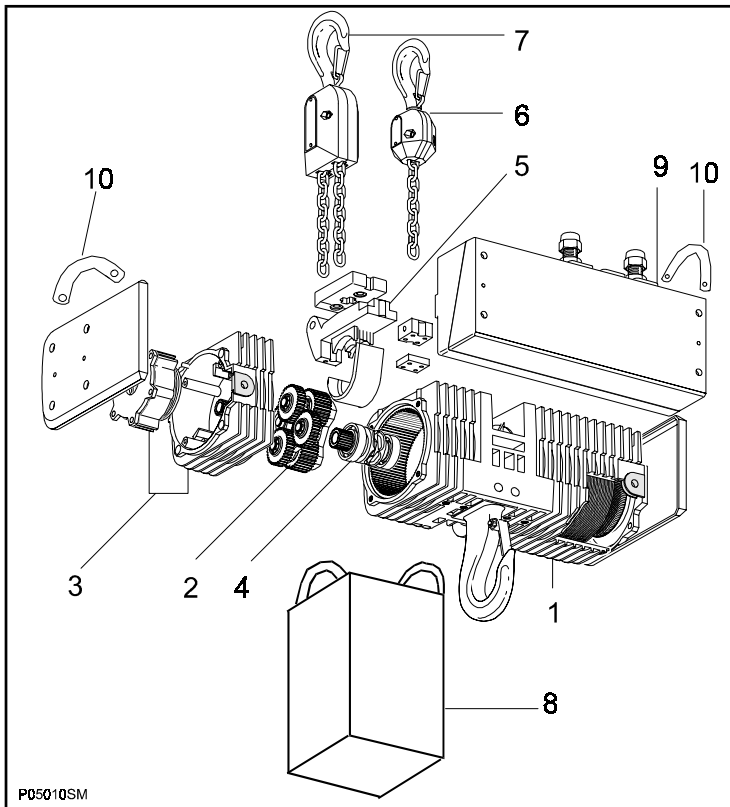

- 1- Main casing
- 2- Gears
- 3- Brake/limiter/housing
- 4- Chain sprocket with output shaft
- 5- Chain guide
- 6- 1-fall hook block/hook
- 7- 2-fall hook block/hook assembly
- 8- Chain bucket
- 9- Electric box
- 10- Handles

Identification plate

VERLINDE		VERNOUILLET 28501 FRANCE	
Type	<input type="text"/>	F.E.M.	<input type="text"/> 1995
1 <input type="checkbox"/>	kg	<input type="text"/> m/min	<input type="checkbox"/> m
2 <input type="checkbox"/>	kg	N• 9500000	<input type="checkbox"/>
<input type="checkbox"/>	4,8 x 12,5 mm	CL : DAT	DIN 5684
Mot <input type="checkbox"/>	~ <input type="text"/>	C.I. <input type="text"/>	Ins CL <input type="checkbox"/> F
<input type="checkbox"/>	V	Hz <input type="text"/>	A <input type="text"/> kW <input type="text"/>
<input type="checkbox"/>	<input type="text"/> tr/min	M _f <input type="text"/>	<input type="checkbox"/> N _m CE

P05033VL

The hoist which you have just purchased should only be used with a maximum load equal to the nominal load (refer to the table above).

The length of its useful service life depends on the demands placed on it, the average operating time, the number of start-ups and its maintenance.

6-3 Hoist dimensions and weight

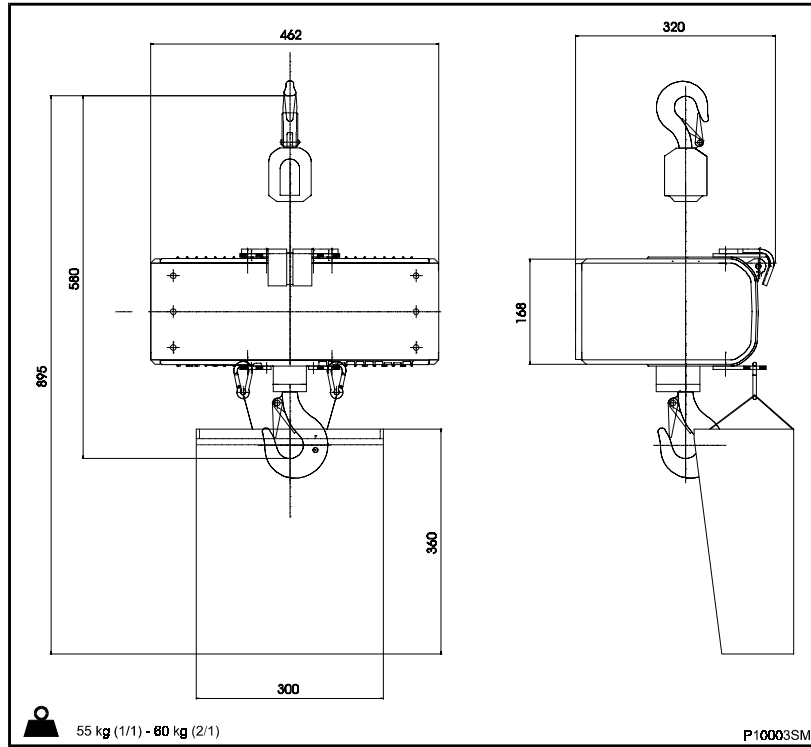

6-4 Environmental data

Ambient temperature: -20°C to +40°C
Protection class: IP55 as standard
Side pulling angle: 3 degrees maximum

Impact on the environment:

Sound level: 70 decibels

6-5 Operation of the hoist

Kinematic chain

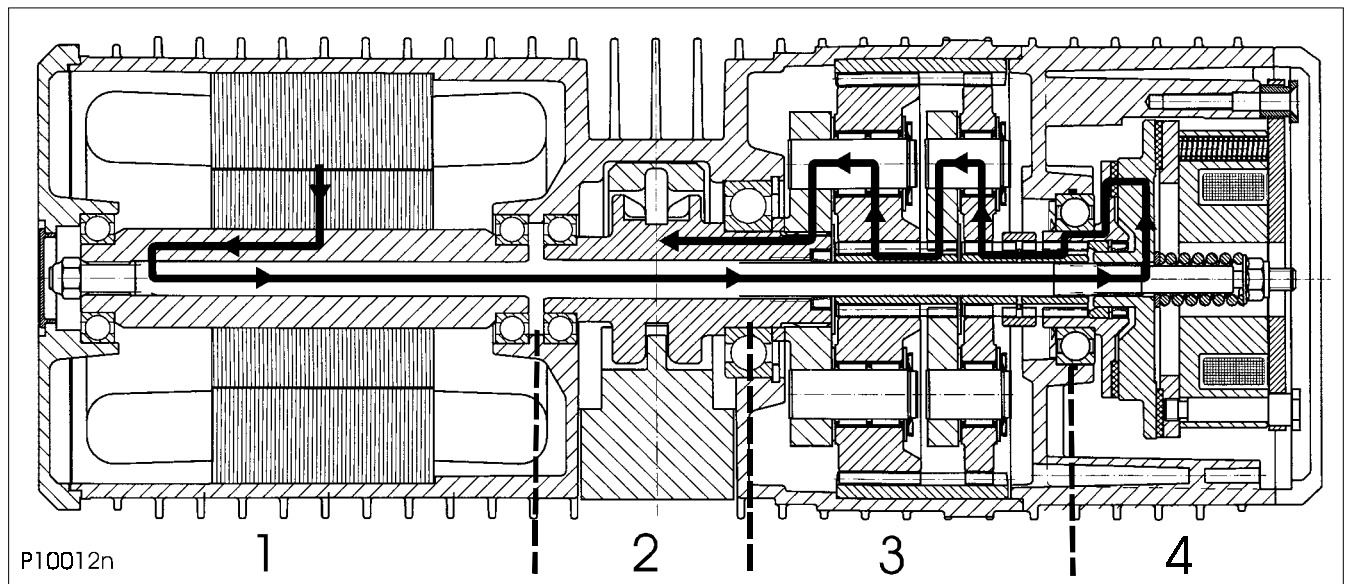

- | | |
|-------------------|------------------|
| 1. Motor | 3. Gear |
| 2. Chain sprocket | 4. Brake/limiter |

Technical advantage

The position of the limiter allows, should it slip, the load to be held in all cases by releasing the control box button.

7- Brake/limiter assembly

7-1 Operation

The parts of the limiter are mounted on the gear input shaft (1). Other brake parts are mounted on the brake cap.

The spring (2) keeps a pressure between the limiter lining (3) and the brake disc (4).

The nut (5) maintains the assembly on the gear input shaft.

When the coil (6) is energized, during lifting or lowering, it is pulled against the anchor disk (7) releasing the brake disk (4) (there is a play X' for this purpose).

The disks (3 and 4) turn freely, transmitting the movement to the pinion (8).

Braking occurs when the coil is no longer energized and the springs (9) drive back the coil and its lining against the brake disk (4).

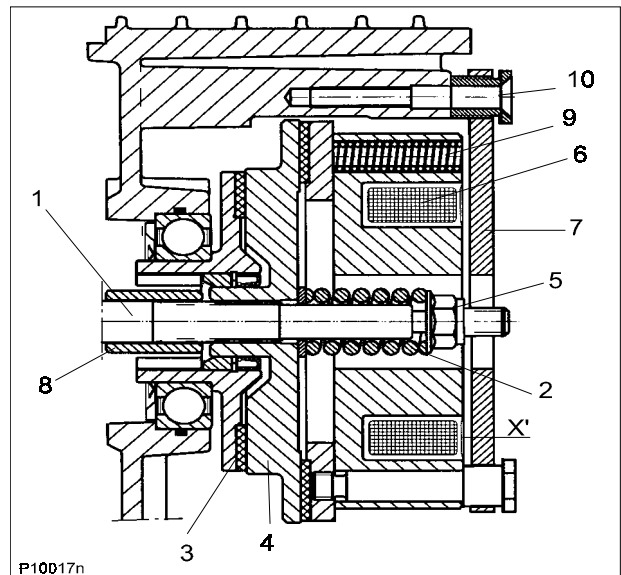

7-2 Adjustment of the limiter:

1. Hook a load of 1.4 times the nominal load onto the hoist.
2. Remove the brake endcap and the sealing.
3. Raise the load at slow and fast speed.
4. Use a key to turn the adjusting nut (5) in the required direction.
 - Turn the nut clockwise to increase the torque.
 - Turn the nut counterclockwise to decrease the torque.
5. Repeat steps 3 and 4 until the load can barely be lifted at fast speed. The limiter is now adjusted.
6. Fit the sealing and the brake endcap.
7. Check, at fast speed, the lifting of a nominal load.

Note: That when the limiter is adjusted the brake end cap must be removed and the motor must be running.

Do not touch the moving components. Before pressing the "lift" button on the control box, check that there is nothing in contact with the adjusting nut (key, for example).

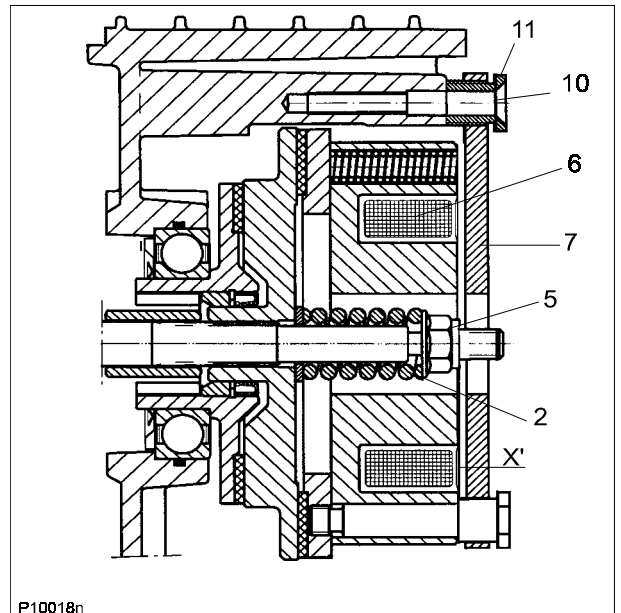

7-3 Adjustment of the brake

1. Before starting the adjustment, remove the load and switch off the power supply.
2. Remove the brake endcap and the sealing.
3. Use feeler gauge to measure the air gap (X') between the anchor disk (7) and the electromagnet at at least three points around the electromagnet.
4. To adjust the brake :
 - Unscrew one of the locking screw (10).
 - Adjust the air gap by turning the adjusting screw (11) counterclockwise to reduce the airgap, clockwise to increase it.
 - Tighten the locking screw (10).
 - Make the same operation with the 2 other adjustment points.
 - Control the air gap adjustment all around the magnet.
5. Check the operation of the brake
6. Fit the sealing and the brake endcap

Brake air gap

Between anchor disk (7) and coil (6)

Minimum air gap (mm)

$X' = 0.2$

Maximum air gap (mm)

$X' = 0.5$

Note: To replace the brake/limiter assembly, the electromagnet supply wires inside the electric box must **first of all** be disconnected.

8 - Lifting assembly

CAUTION !

Only a genuine, manufacturer's chain may be used.
 Never use the lifting chain as a sling.
 Never twist the lifting chain.
 Do not bundle the chain into the chain bucket.
 Always keep the chain clean and oiled and check that it is in good condition every day.

8-1 Slack fall stop (in the chain bucket)

CAUTION !

The slack fall stop is a safety component, not a functional one.
 A correct length of chain is required to avoid using it.

REMOVAL:

1. Remove the pin.
2. Remove the tube from the stop.
3. Remove the two halves of the stop.

REPLACEMENT:

1. Check that there is at least 150 mm of chain under the slack fall stop.
 Position the two halves of the stop around the chain.
2. Insert the tube around the stop.
3. Insert the pin.

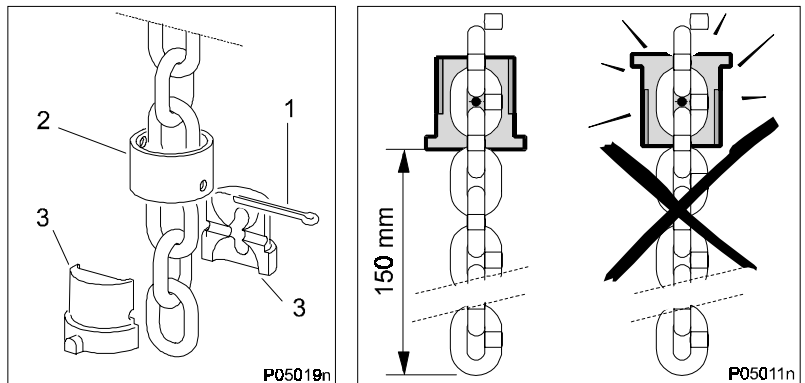

Note: Make sure that the stop is correctly fitted. The locking tube should be turned towards the hoist.

8-2 Chain « certificate »

Chain type:	standard
Diameter (d) / pitch (t):	6.8 mm / 17.8 mm
Class:	DAT
Grade:	H8S or HE G80 RAS
Maximum working stress:	135.1 N/mm ²
Hardened surface:	580 or 700 HV
Thickness:	0.14 to 0.28 mm
Standard:	DIN 5684 - 8
Marking (6 x t):	□1 or □16 H 8 S or A 8
Maximum working load, 1 fall:	1000 kg
Breaking load:	58,1 kN
Maximum breaking stress:	800 N/mm ²
Total breaking elongation:	>10% min.
Weight for 1 m :	1.08 kg

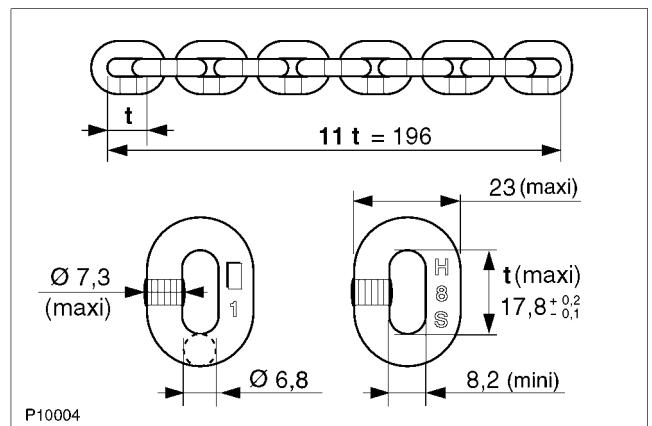

Measuring the wear on the chain

This should be done by measuring the dimensions, at several points of the chain, of one link (d) and (t), and over 11 links (11 t).

Maximum wear allowed:

Minimum link thickness allowed (d):	6,1 mm
Maximum pitch allowed (t):	18,7 mm
Maximum length allowed (11 t):	199,7 mm

If these limits are exceeded, **the chain must be replaced immediately**. In this case, the wear on the guide chain and chain sprocket should also be checked and they should be replaced if necessary. If a single link is defective in any way whatsoever, **the chain must be replaced**.

8-3 Removal of the chain

1-fall chain:

1. Remove the load from the hook.
2. Disassemble the hook block.
3. Lower the chain into the chain bucket.
4. Remove the chain bucket and unscrew and remove the lower chain guide.

2-fall chain:

1. Raise the hook block to about 30 cm from the hoist body.
2. Remove the chain bucket.
3. Carefully remove the lower chain guide.
4. Disassemble the fixed point of the chain.
5. Remove the 2-fall hook block, without disassembling it, letting the chain run through it.
6. Let the rest of the chain slide through the chain sprocket.

8-4 Replacement of the chain

The chain should always be fitted using the flexible plastic insertion tool (1). Use of this tool always ensures that the chain is fitted correctly.

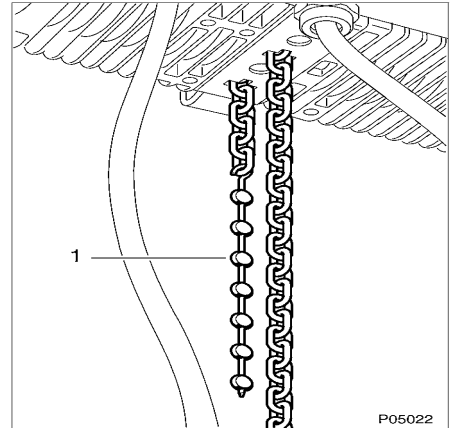
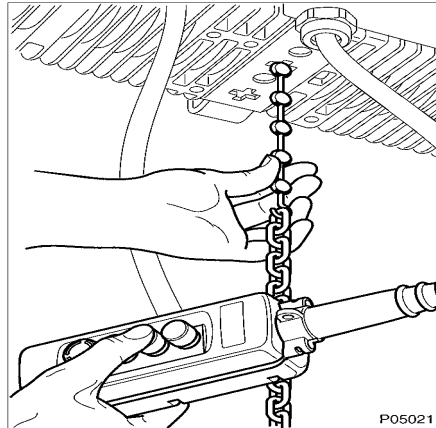

1-fall chain:

1. Insert the last link in the small plastic hook of the insertion tool.
2. Insert the other side of the tool in the sprocket, chain bucket side.
3. Raise the chain at slow speed so that the tool and the chain come out the other side of the sprocket.

Note: the welds (1) of the vertical chain links should be towards the chain sprocket.

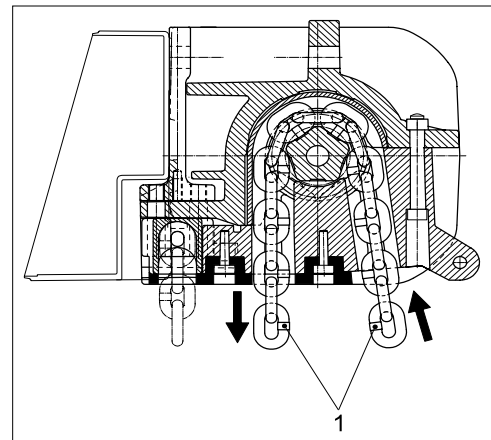

2-fall chain:

1. Insert the last link in the small plastic hook of the insertion tool.
2. Insert the other side of the tool in the sprocket, chain bucket side.
3. Raise the chain at slow speed so that the tool and the chain come out the other side of the sprocket. Continue until about 50 cm of chain are visible.
4. Put the chain through the idler sprocket, **taking care not to twist the chain**
5. Carefully remove the chain anchor (5) removing the 4 screws. Take out the pin (6).
6. Insert the end of the chain into the hole of the chain anchor.
7. Insert the pin (6) into the hole of the chain anchor.
8. Insert the chain anchor and tighten the 4 screws (torque 20 Nm).

Note: the welds (1) of the vertical chain links should be to the side away from the idler sprocket.

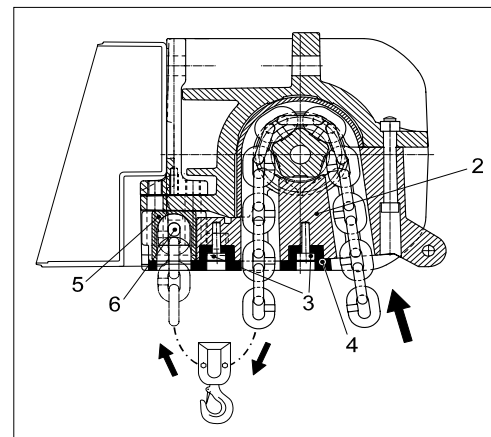

8-5 Hook « certificate »

Load capacity (kg)	FEM group	Test load (kg)	Number of falls	Minimum ruin load (kg)	Marking Class	Dimensions (mm)										
						Ø M	Ø a1	a2	a3	b1	b2	e1	h1	h2	t1	t2
630	2 m	1260	1	3970	025 T	16	36	26	41	22	19	96	28	24	38	13
1000	1 Bm	2000	1	5000	025 T	16	36	26	41	22	19	96	28	24	38	13
1250	2 m	2500	2	7875	05 T	20	43	34	49	29	24	105	37	31	43	14
2000	1 Bm	4000	2	10000	05 T	20	43	34	49	29	24	105	37	31	43	14

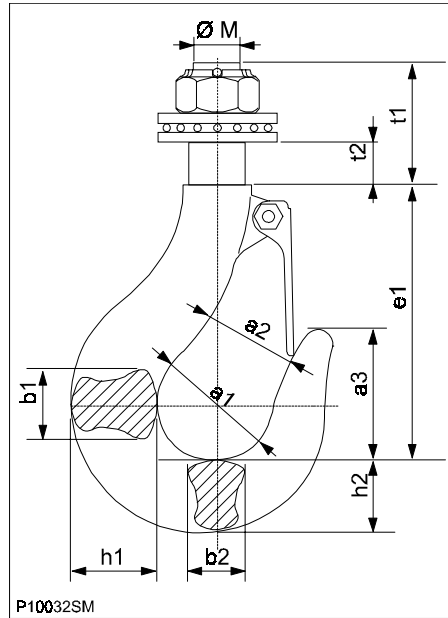

Mark: ISO 2766
DIN model number: 15401

DIN 15400 class: T
DIN 15401 material: 35 CD 4

8-6 Suspension hook

REMOVAL:

1. Remove the screw and the locking plate.
2. Remove the two pins.
3. Take the hook out.

REPLACEMENT:

1. Put the hook into its housing.
2. Place the two pins inside the hook
3. Fit the screw and the locking plate without forgetting the safety washer.

(Refer to paragraph 10-4 for the tightening torque).

Note: The hook should be set depending on 1/1 and 2/1 revings.

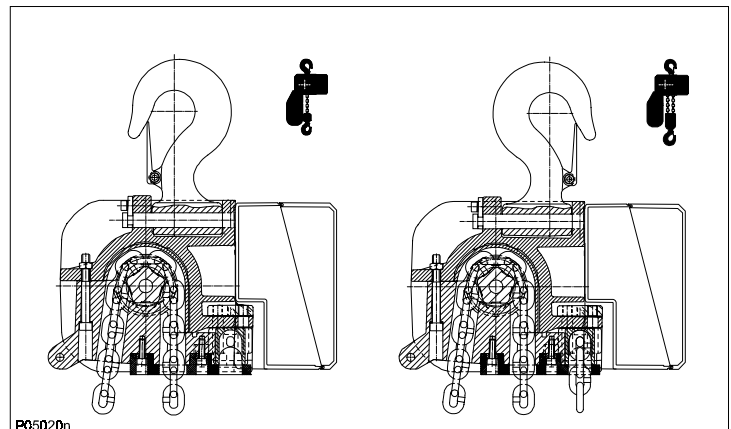

8-7 Measurement of the wear on the suspension and lifting hooks

The wear on the suspension and lifting hooks (dimension **a2** and **32.5**- see drawing at top of page) should be checked regularly.

Damaged safety catches should be replaced immediately.

If the maximum dimension (**a2**) on the lifting hook is greater than the initial dimension by more than 15%, the hook should be replaced immediately.

• Bottom hook

Class: 025 05
a2, max. allowed: 30 mm 39 mm

• top hook

maximum allowed for the throat opening (dimension)32.5mm): 37mm
If it found to be worn please contact an authorised agent.

9 - Electricity

CAUTION!

Before any operation on the electric box, check that the hoist supply is disconnected.
An isolator switch should be installed at a maximum of 6 meters from the hoist.

9-1 GENERALS

- The customer must supply the power supply cable, the fuses and the main isolator switch (refer to the wiring diagram).
- Check that the mains system is correct for the hoist.
- Check that the voltage does not vary by more than $\pm 5\%$ from the nominal value.
- Neutralize the electric sources.
- Make sure that the main hoist electric power switch is off.
- Do not use binding posts (luster terminals, etc.) to connect the power supply cable to the hoist.
- Do not use rigid cable or cable with a section different to that indicated below to supply the hoist.
- Never shunt the isolators, the power switches or the limitation or prevention equipment.
- Never block, adjust or remove the limit stops or switches to go higher or lower than these allow.

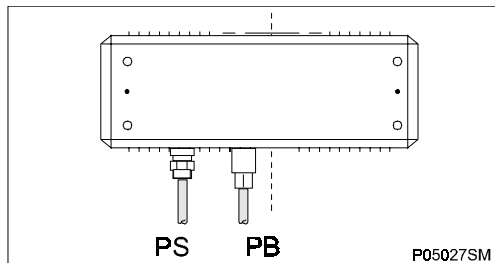

PS: Power supply
PB: Control box connection

Minimum cable sections:

Power supply:	1.50 mm ²	Fuses for control voltage	T 1,25 A
Auxiliary current:	0.75 mm ²	Fuses for power supply	
Control box/hoist:	1.00 mm ²	- 230 V	10 A
		- 400 V	10 A

9-2 LOW VOLTAGE CONTROL

9-2.1 ELECTRICAL CONNECTION

Connection:

1. Remove the control box cover.
2. Insert the cable (PS) into the box through the PG cable gland.
3. Connect phases L1 - L2 - L3, and the ground wire to the terminal board X1(see 9.2).
4. Check that the terminals are correctly tightened.
5. Close the box.
6. Check the hoist operation.

CAUTION!

The supply cable must be equipped with a power switch or an isolator in conformity with the regulation.
The supply cable and main isolator switch must be supplied by the costummer.

9-2.2 Printed circuit board (2 lifting speeds with emergency stop)

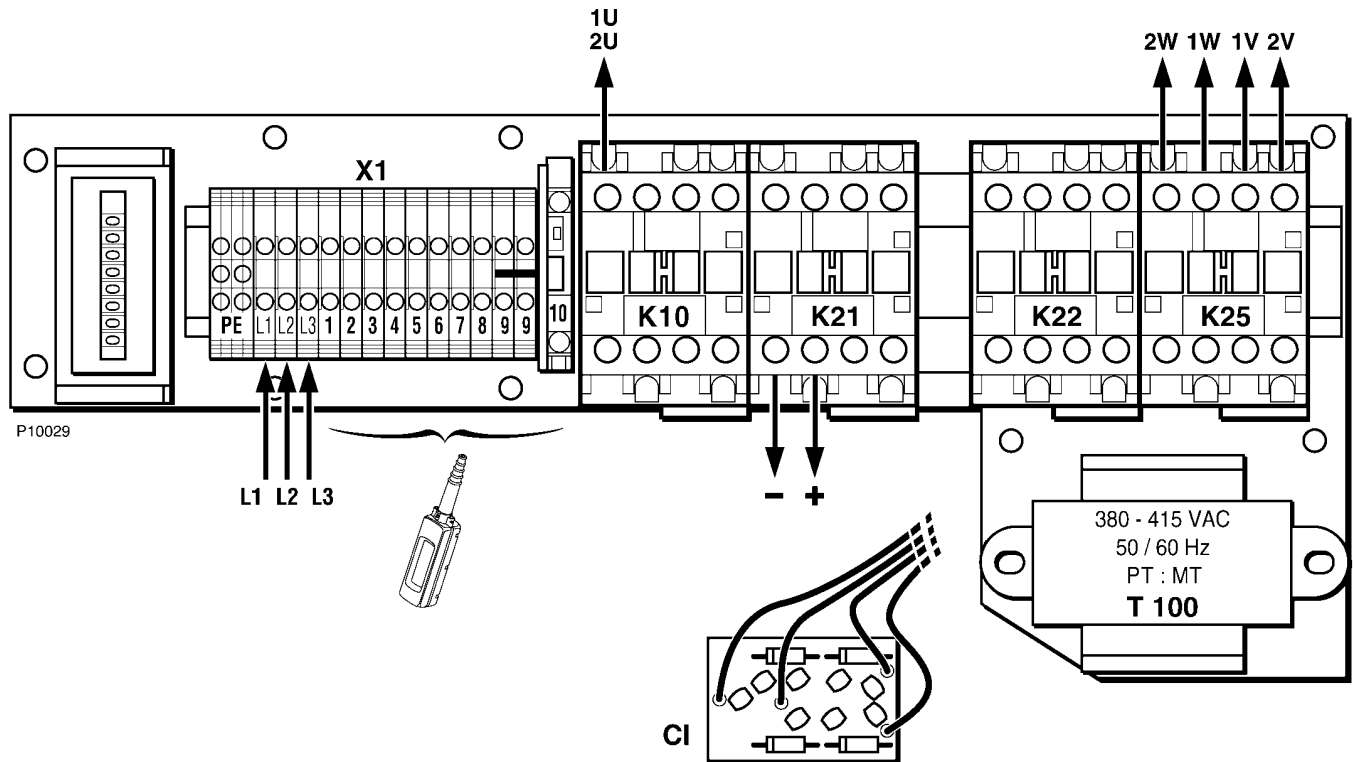

HOIST SUPPLY

L1	hoist supply	
L2	hoist supply	
L3	hoist supply	
K21-2	- brake	
K21-4	+ brake	
K10-1	1U-2U	motor supply
K25-R3	1V	motor supply
K25-3	2V	motor supply
K25-R1	1W	motor supply
K25-1	2W	motor supply

GROUND WIRES

ground terminal, 4 connections	
PE	motor
PE	p.c. board
PE	trolley connection
PE	power supply

TROLLEY CONNECTION (X24)

K10-1	L21	electric trolley supply
K10-3	L22	electric trolley supply

CONTROL BOX PLUG (X23)

1	Common control box
2	Lifting
3	Lowering
4	Speed selector
5	Emergency stop
6	Right, electric trolley
7	Left, electric trolley
8	Travelling speed selector

PRINTED CIRCUIT BOARD

Terminal X1	
10	Common
1	Lifting
4	Lowering
6	Right, electric trolley
7	Left, electric trolley
8	Travelling speed selector
9	Earth
1-2	thermal protection <i>(replace the shunt)</i>
2-3	top limit switch <i>(replace the shunt)</i>
4-5	bottom limit switch <i>(replace the shunt)</i>
10	Fuse T 1,25 A
K10	Emergency stop contactor
K21	Lifting contactor
K22	Lowering contactor
K25	Speed selector
T100	Control transformer
9	Counter (Option)
K22-22	Counter (Option)

9-2.3 Power diagram

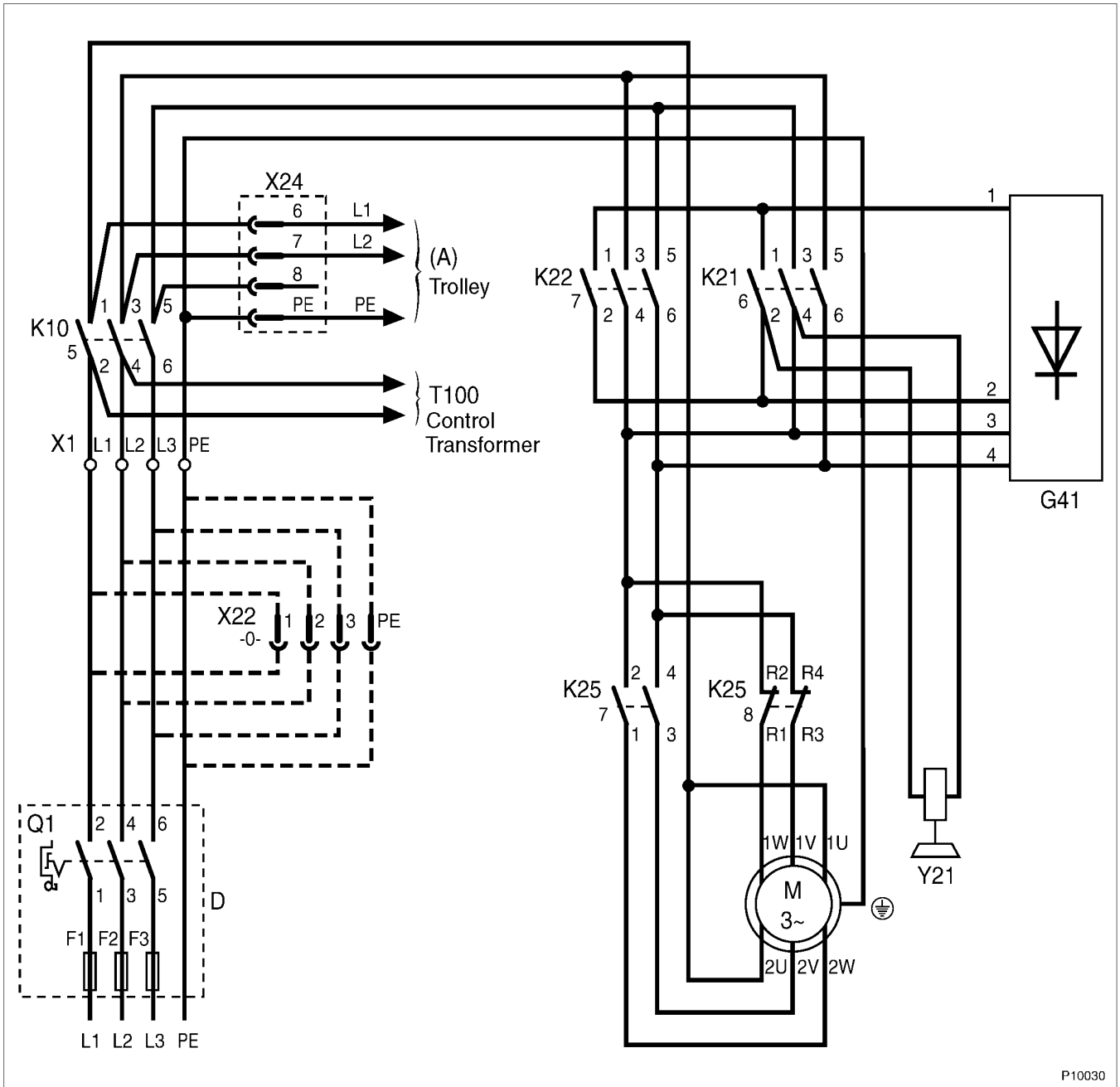

P10030

D	Supplied by customer
A	Electric trolley
Y21	Brake
F1-F2-F3	Fuse (customer)
M	Motor
Q1	Power switch (customer)
K10	Emergency stop contactor
K21	Lifting contactor
K22	Lowering contactor
K25	Speed selector
T100	Control transformer
X1	Terminal board
X22	Supply connection plug (OPTION)
X24	Trolley connection plug
G41	Rectifier

CAUTION !

The supply cable must be equipped with a power switch or an isolator in conformity with the regulation.
The supply cable and the main isolator switch must be supplied by the customer.

9-2.4 Control diagram (2 lifting speeds with emergency stop)

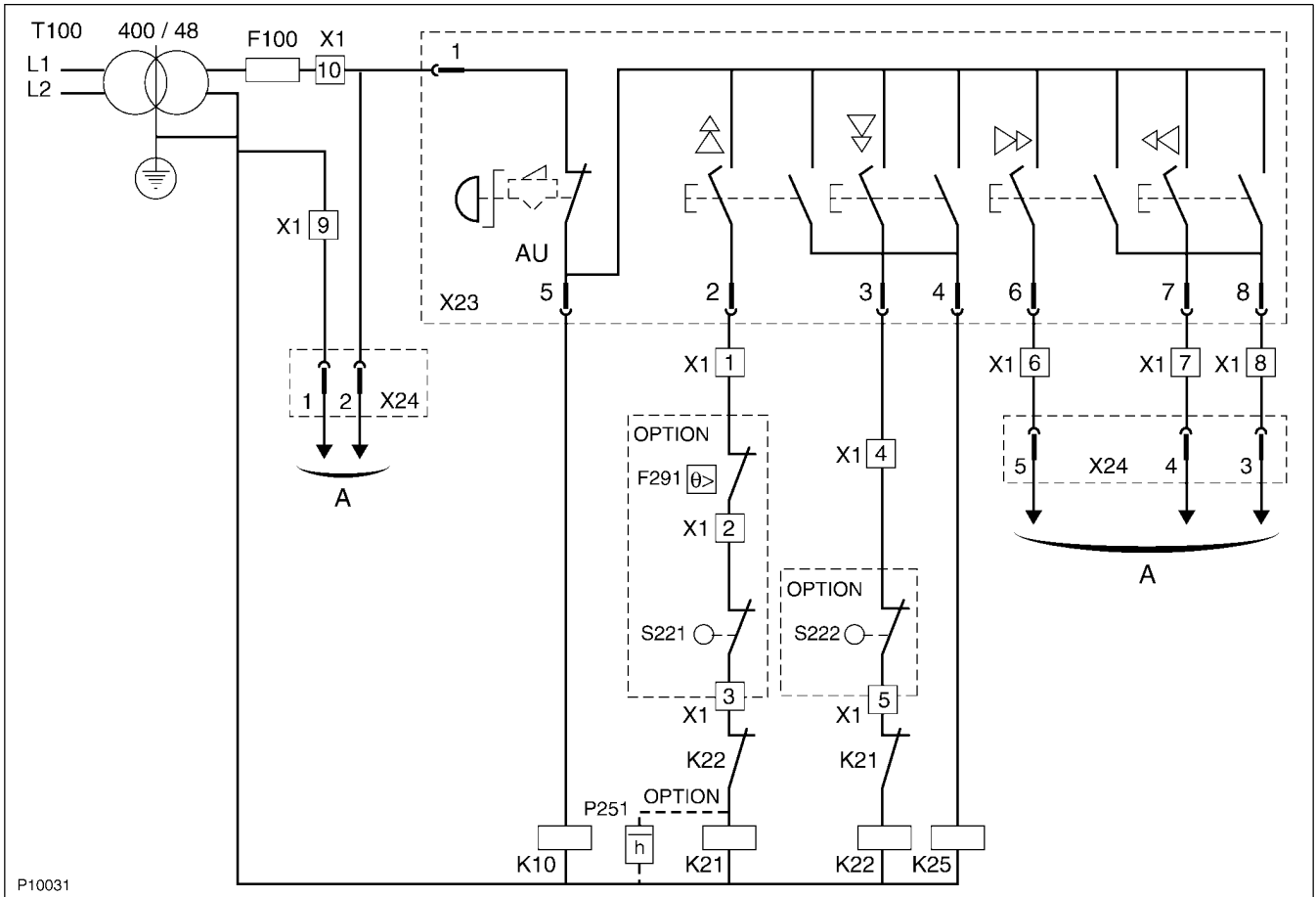

- A Electric trolley
- AU Emergency stop
- T100 Control transformer
- F100 T 1,25 A fuse
- K10 Emergency stop control
- K21 Lifting control
- K22 Lowering control
- K25 Speed selector
- X1 Hoist terminal

- X23 Control box plug
- X24 Trolley connection plug
- F291 Bimetal thermal cutoff
- S221 Top limit switch
- S222 Bottom limit switch
- P251 Hour counter (OPTION)*

***Note:** The counter add only the times during lifting operation.

Do not use the controls needlessly (avoid inching - stop-start operation).

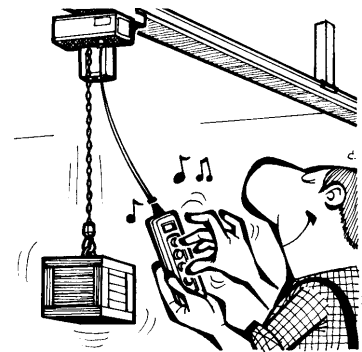

9-3 DIRECT CONTROL

ACF board (Option)

The ACF board control electronically the brake. It enables a rapid brake acceleration. (As the hoist is not equipped with contractor control electrics).

ACF 1, 1 lifting speed

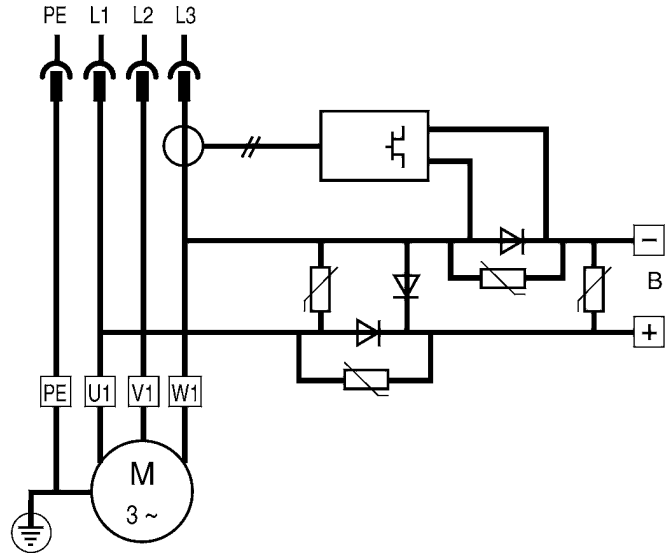
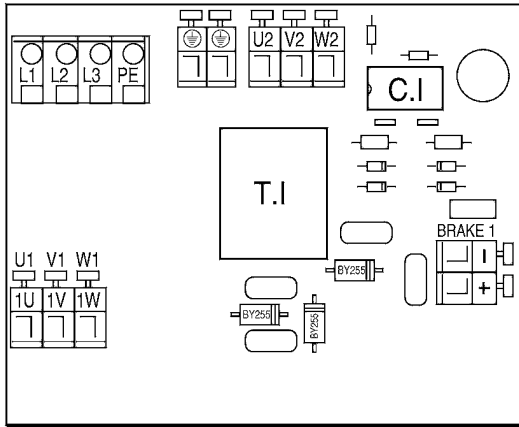

POWER SUPPLY :
L1 L2 L3 PE

MOTOR CONNECTION :

230V	U1 W2	400V	U1	U2
	V1 U2		V1	V2
	W1 V2		W1	W2

B- BRAKE :
+ - brake

ACF 2, 2 lifting speed

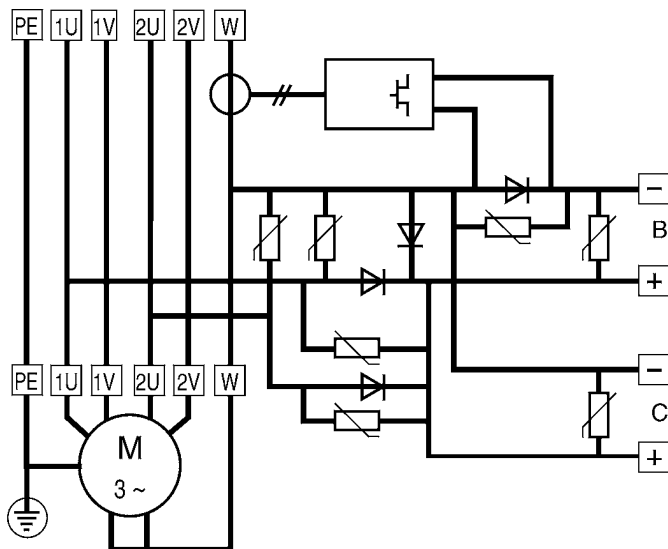
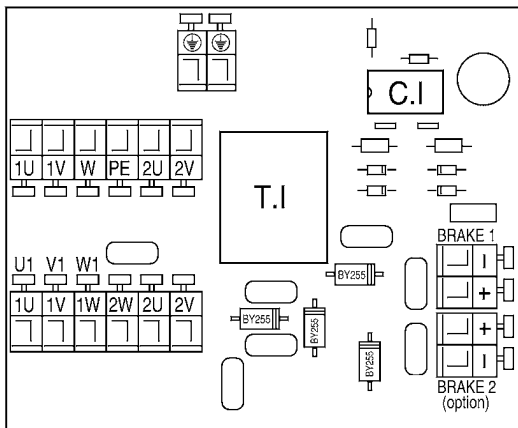

POWER SUPPLY :
1U 1V W 2U 2V PE

MOTOR :
1U 1V low speed
2U 2V high speed
1W 2W common

B- MAIN BRAKE
C- EMERGENCY BRAKE (OPTION)
+ - brake

10 - Maintenance - Replacement

10-1 Maintenance table

Check	Interval	Qualification of the customer's personnel
Brake operation	Daily	Operator
Visual inspection of the chain	Daily	Operator
Suspension of the control box by the steel wire	Daily	Operator
Cleanness and lubrication of the chain	Monthly	Operator
Limiter operation	Monthly	Operator
Measuring of the wear on the chain	Every 3 months	Operator
Measuring of the wear on the hooks	Every 3 months	Operator
Tightening of the hook block screws	Every 3 months	Operator
Checking of the locking plate screws	Every 3 months	Operator
Lubrication of the idler sprocket	Annually	Operator
Checking of the screw tightening torques and checking for signs of corrosion	Annually	Qualified mechanic
Adjustment of the limiter and brake	Annually	Qualified mechanic
Lubrication of the gears	Lubricated for life	

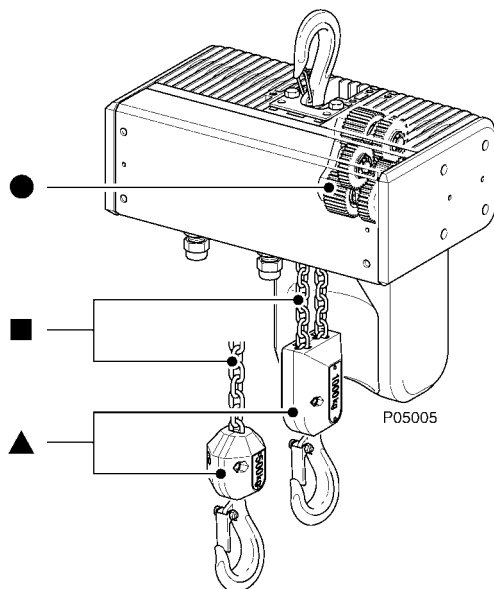

CAUTION! These intervals should be shortened if the hoist is used a lot, if it is used with maximum loads or in difficult ambient conditions.

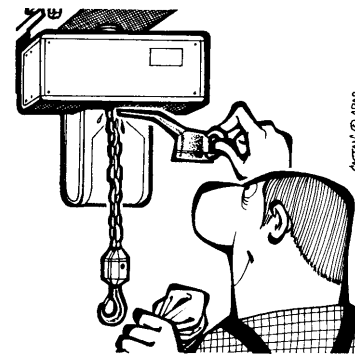

Oil the chain regularly.

10-2 Lubricants

Lubrication point	Specifications	Possible brands	Quantity
■ Chain	Oil or liquid grease	Chain lubricating fluid (Ceplattyn or similar)	As required
⊃ Idler sprocket slide bearing + bearing	Grease (without MoS2) KP 2 (DIN 51 502) Soap-based lithium Approx. drip point + 260°C Worked penetration 265 - 295° Operating temperature - 20°C à + 130°C	Aral : Aralub FK 2 BP : BP Energrease LS - EP 2 Esso : Unirex N2 Mobil : Mobilgrease HP Shell : Shell Alvania EP Grease 2 DEA : Paragon EP 2 Fuchs : Renolit Duraplex EP 2	As required
● Gears	KP 0 K grease (DIN 51502) Soap-based lithium + MoS 2 Approx. drip point + 180°C Worked penetration 355 - 385° Operating temperature - 30°C à + 130°C	Tribol : Molub Alloy multi-purpose grease Aral : Aral P 64037 grease Aralub PMD0 BP : Multi-purpose grease L 21 M Esso : Multi-purpose grease M Mobil : Mobilgrease Special Shell : Shell Retimax AM Texaco : Molytex grease EP 2 Fuchs : Renolit FLM0	0.2 liter

10-3 Spare parts replacement table

CAUTION! Disconnect the power supply before replacing any parts.

Spare part	To be replaced by	Qualification of the personnel
Upper chain guide	Authorized manufacturer personnel	Qualified mechanic
Idler sprocket	Authorized manufacturer personnel	Qualified mechanic
PG cable gland	Authorized manufacturer personnel	Qualified electrician
Motor input shaft + adjusting nuts	Authorized manufacturer personnel	Qualified mechanic
Motor endcap	Authorized manufacturer personnel	Qualified mechanic
Gearing (1st/2nd stage)	Authorized manufacturer personnel	Qualified mechanic
Brake cap/endcap sealing	Customer	Qualified mechanic
Other sealings and O-rings	Authorized manufacturer personnel	Qualified electrician
Brake-limiter	Authorized manufacturer personnel	Qualified mechanic
Brake endcap	Customer	Qualified mechanic
Lower chain guide	Customer	Qualified mechanic
Rubber buffer	Customer	Qualified mechanic
Electric box	Authorized manufacturer personnel	Qualified electrician
PC-board	Authorized manufacturer personnel	Qualified electrician
Plugs	Customer	Qualified electrician
Chain	Customer	Qualified mechanic
Chain bucket	Customer	Qualified mechanic
Slack fall stop	Customer	Qualified mechanic
Suspension hook	Customer	Qualified mechanic
Hook block (1/1; 2/1)	Customer	Qualified mechanic
Control box	Customer	Qualified electrician

Once a part has been replaced, check the operation of the hoist (*refer to 5.2: Installation*).

10-4 Screw tightening torques (Nm)

	M5	M6	M8	M10	M12	Plastic*
Standard screws	6	10	24	48	83	1
Self-tapping screws	5	8	20	40	72	1

(*) Screws for fixing plastic parts

10-5 Discarding the hoist

Once the hoist has been used for the FEM class duration, all of the components must be checked by an authorized agent or by the manufacturer. **The hoist should no longer be used, unless agreement is obtained from the authorized agent or the manufacturer.**

Remove all greases and oils from the hoist before discarding it.

11 - Troubleshooting

Problem	Cause	Solution
The chain hoist does not work	The emergency stop button is activated Triggered fuse Temperature control (<i>optional</i>) activated Contactor terminal screws loose Main switch is off	Deactivate it Replace the fuse Allow to cool down Tighten them Turn it on
Impossible to lift the load	Overload Limiter worn or incorrectly adjusted	Reduce the load Adjust or replace it
Braking path of more than 10 cm	Brake lining worn	Adjust the brake and replace the brake components if necessary
The travel direction does not correspond to that indicated on the control box	The power supply is incorrectly connected	Change two phases of the power supply
Abnormal noises while the load is being moved	The chain components are not lubricated Chain is worn Sprocket or chain guide is worn Idler sprocket is worn A supply phase is missing	Lubricate the components Replace it Replace the sprocket or chain guide Replace it Check the connection of the 3 phases

12 - Illustrated catalogue

12-1 Casings

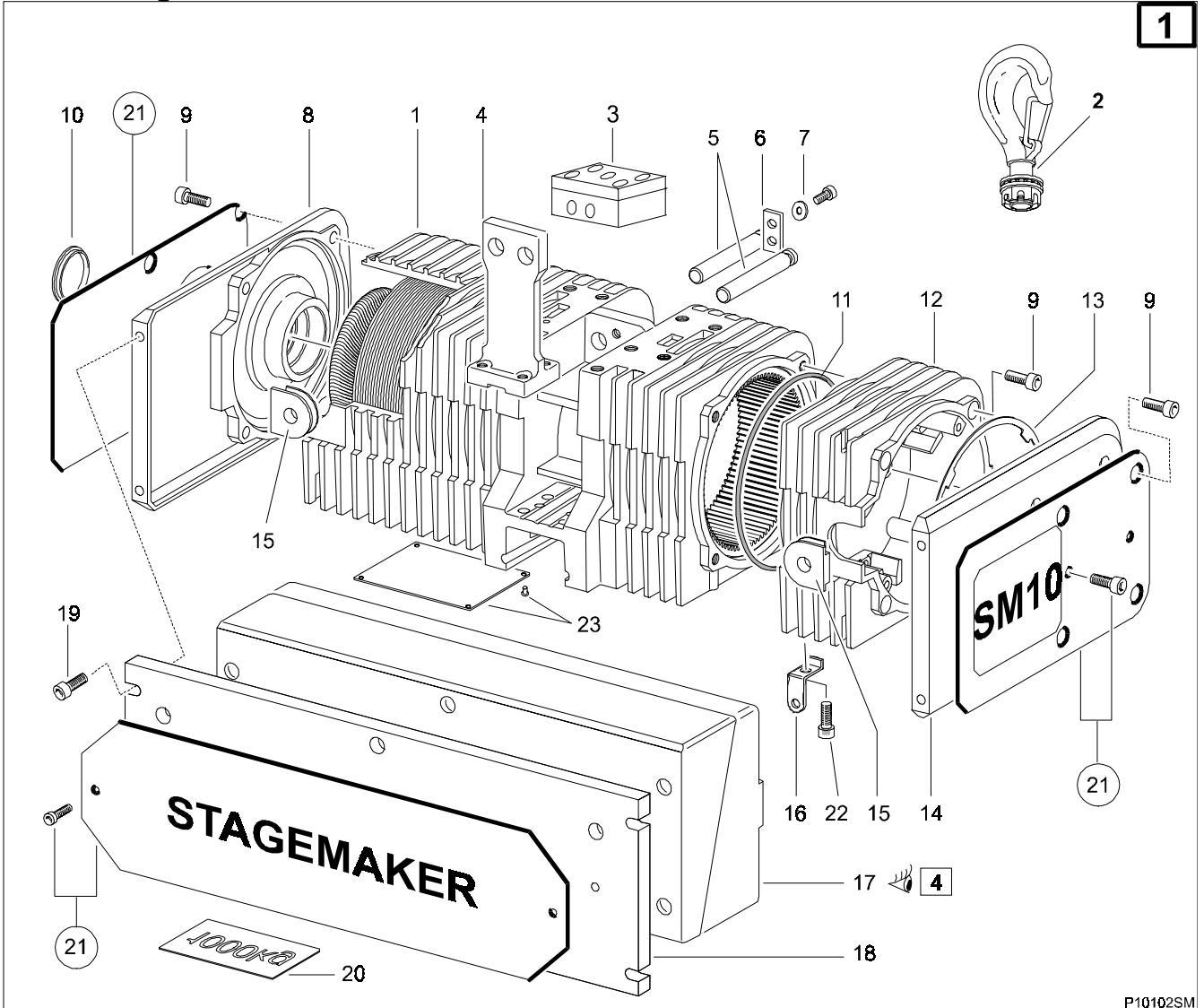

P10102SM

Item	Reference	Description	Qty	Observations
1	2240024	Main casing assembled	1	
2	Rotating hook	1	
3	Rotating hook fixing	1	
4	2242011	Suspension member	1	
5	2247007	Pin	2	
6	2247008	Locking plate	1	
7	830909	Screw M6x20 DIN 912	1	
	8560610	Safety washer	1	
8	2240005	Motor end cap	1	
9	8110051	Screw M6x20 DIN 7500	12	
10	2218001	Cap	1	
11	8381502	O-ring Ø 2 x 150	1	
12	2240004	Brake cap	1	refer to page 12.2
13	2240002	Sealing ring	1	
14	2248007	Brake endcap	1	
15	2218004	Cable guide	2	
16	2213020	Cable fastening bracket	1	
17	Electric box	1	refer to page 12.4
18	2243008	Counter weight	1	
19	8110051	Screw M 6-20st. DIN 7500-E	4	
20	Load plate	1	when ordering, specify the load
21	2246051	Marking assembly SM10	1	(630 to 2000kg)
22	830905	Screw M8-20DIN7500-E	1	

12-2 Mechanism / Brake

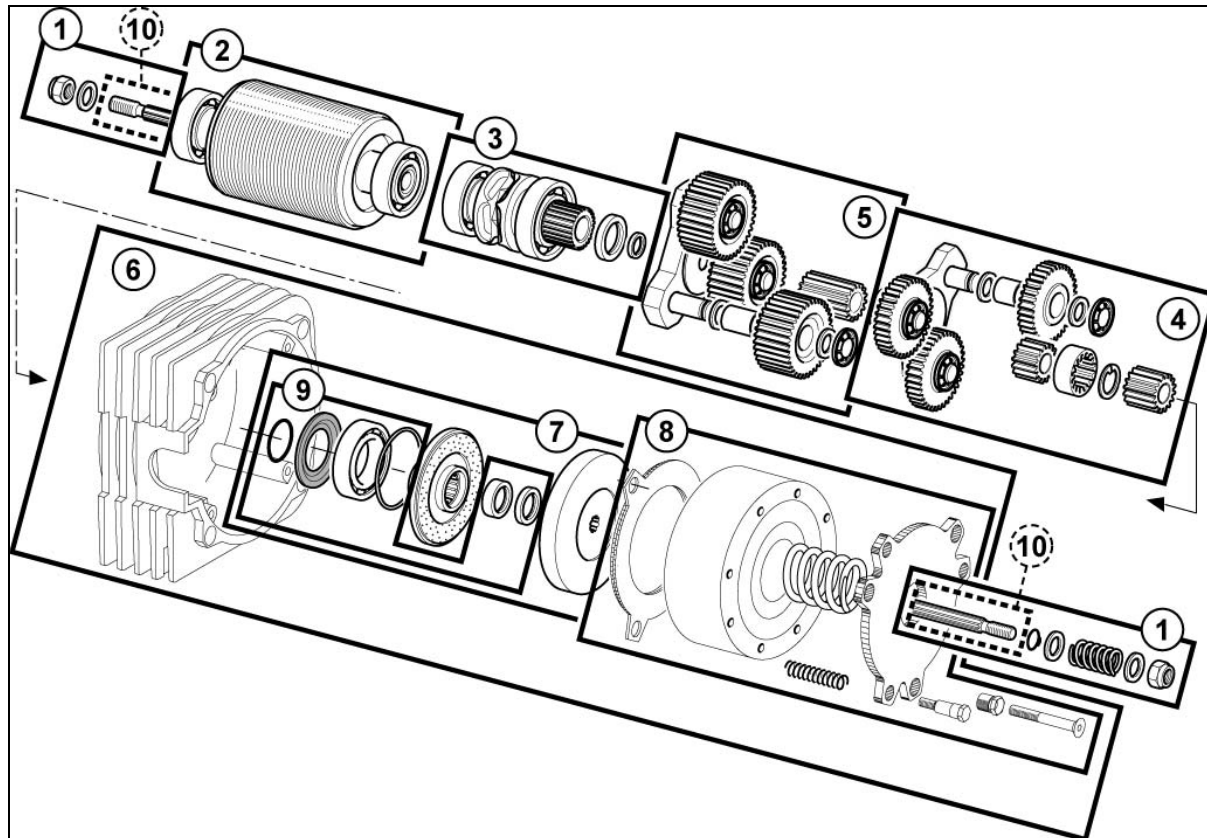

POS	QTY	CODE	Description
1	1	2249940	Limiter spring with motor shaft
2	1	2245025	Rotor assembly - 1 and 2-speed type
3	1	2249941	Chain sprocket assembly
4	1	2249938	Planetary gear train - 2nd step - 8M/MN
4	1	2249951	Planetary gear train - 2nd step - 16M/mn 16
5	1	2249937	Planetary gear train - 1st step -
6	1	2241074	Brake assembly complete with brake cap - 190V/400V
6	1	2241073	Brake assembly complete with brake cap - 100V/230V
6	1	2241072	Brake assembly complete with brake cap - 230V/500V-575V
7	1	2249972	Limiter friction assembly
8	1	2248001	Brake, complete 190V/400V
8	1	2248000	Brake, complete 100V/230V
8	1	2248003	Brake, complete 230V/500V-575V
9	1	2240012	Set of seals for brake cap
10	1	2241501	Three motor

12-3 Lifting assembly

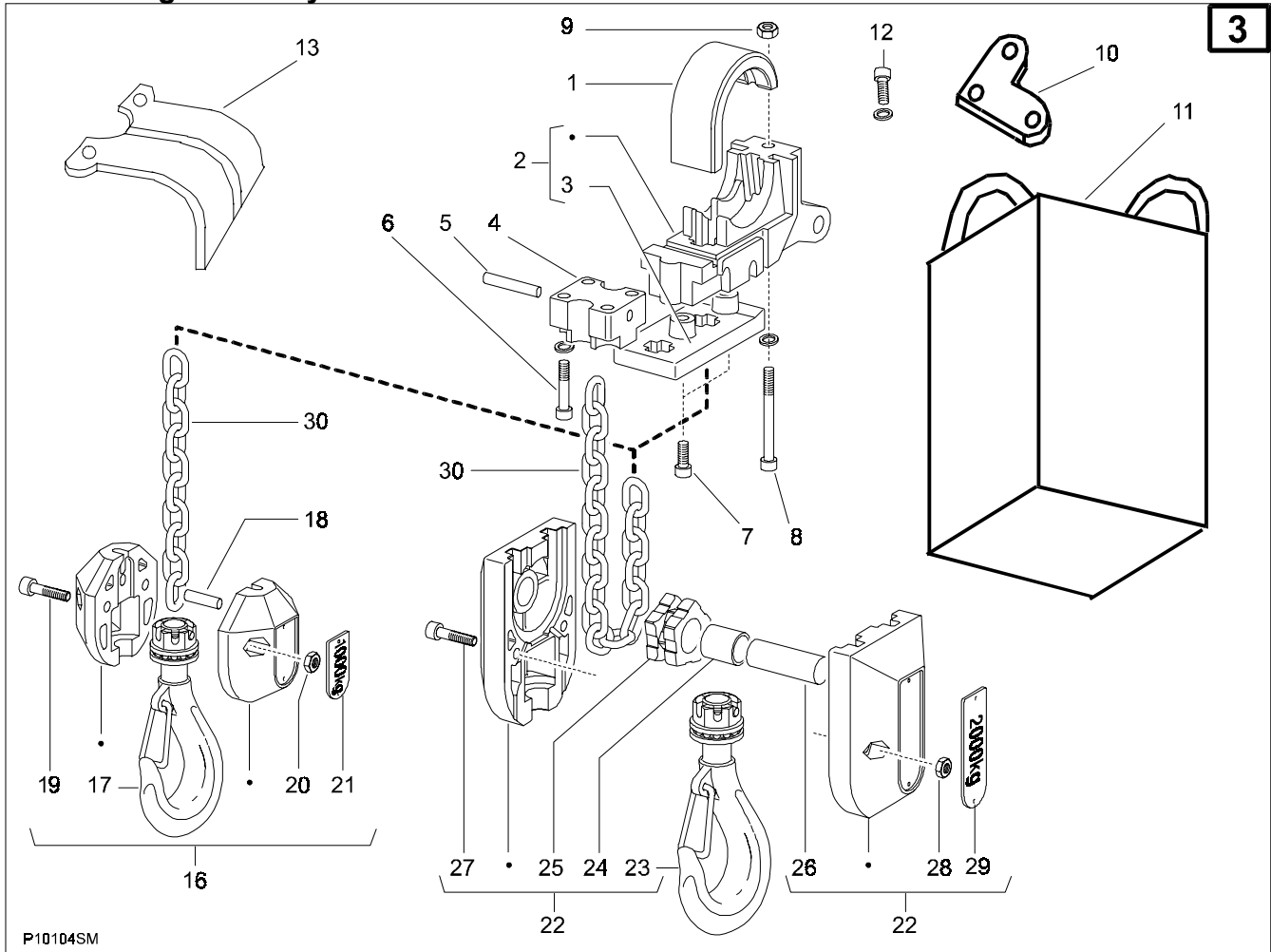

Item	Reference	Description	Qty	Observations
1	2244012	Upper guide chain	1	
2	2244014	Lower guide chain, assembled	1	
3	2244008	Rubber buffer	1	
4	2243522	Chain anchor	1	
5	2243521	Pin	1	
5	2241046	Standard chain bucket	1	
6	8011550	Screw	1	
6	8561016	Safety washer	1	
7	8110051	Screw M 6x20 DIN 7500	2	
8	8010866	Screw M 8x65	1	
9	8030800	Nut M8	1	
10	Fixing plate	4	
11	Chain bag	1	
12	Screw + washer	8	
13	External chain guide	1	
16	2249905	1-fall hook block, assembled	1	
17	2217004	. Lifting hook	1	
18	2242013	. Pin	1	
19	7215455L	. Screw M 8x25	2	
20	831587	. Nut M 8 Nylstop type	2	
21 Capacity plate	1	(630 to 1000kg)
22	2249906	2-fall hook block	1	
23	2242021	. Idler sprocket	1	
24	8192025	. Self-lubricating bush	1	
25	2242022	. Hook housing	1	
26	2242023	. Shaft	1	
27	830901	. Screw M 6 x 30 CHc	2	
28	831588	. Nut M 6 Nylstop type	2	
29 Capacity plate	1	(1250 to 2000kg)
30	2243500	Chain, 6.8 x 17.8	1	

12-4 Electric box

4

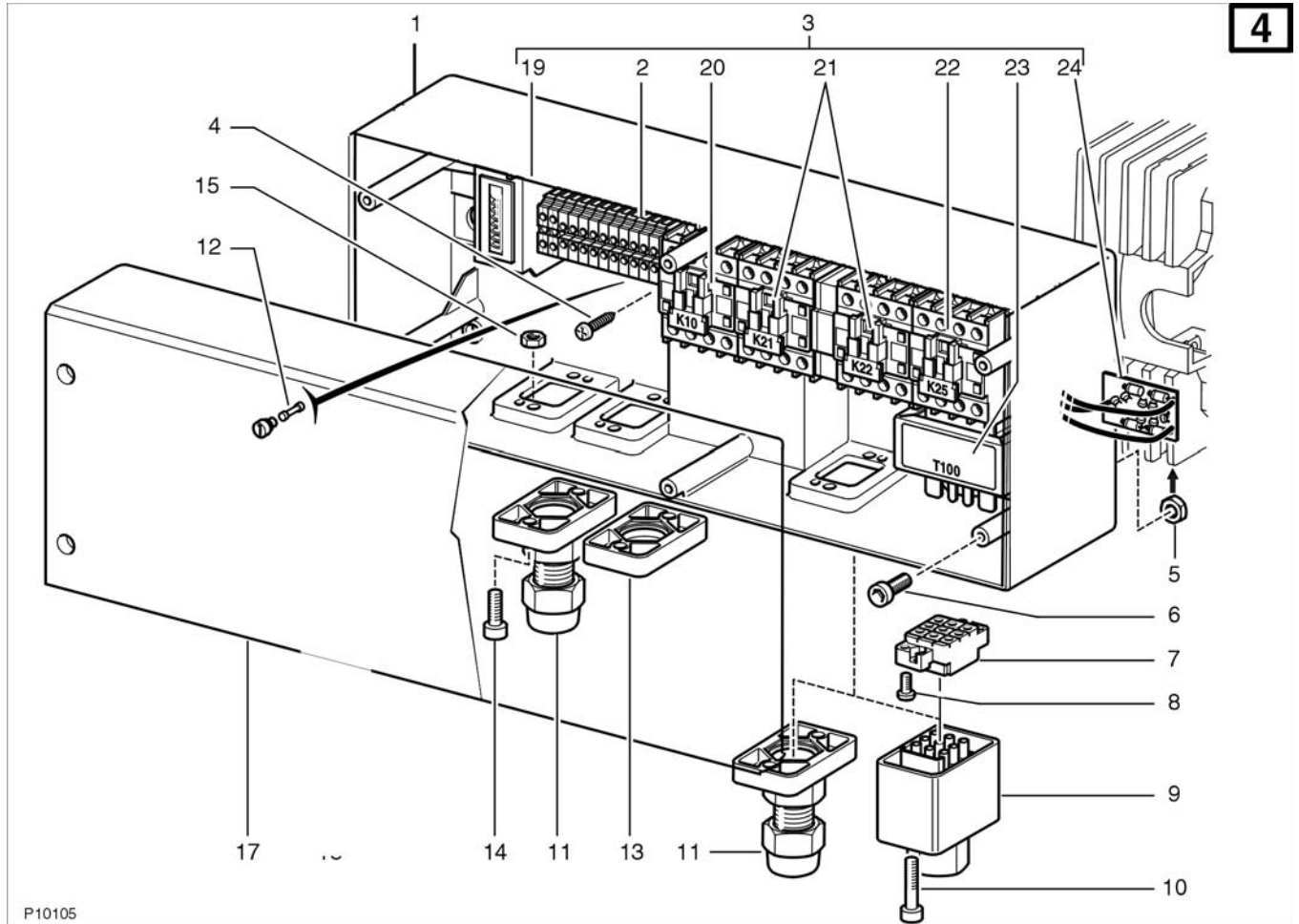

P10105

Item	Reference	Description	Qty	Observations
1	2243010	Electric box complete	1	
2		Terminal board	1	
3	2243004	Equiped circuit board	1	
4	8090410	Self tapping screw 3,5 x 9,5	9	
5	831588	Nut M 6 Nylstop type	4	
6	8110051	Screw M 6x20	4	
7	7285030	Male connector	1	
8	8090411	Plastic screw M 4x10	2	
9	7285038	Plug	1	
10	8010540	Socket head screw M 5x40	2	
11	2213005	PG 16 cable gland	1	
12	833133	Fuse T 1,25 A - 5 x 20	1	
13	2213009	Closing plate	1	
14	830922	Socket head screw M 5x20	4	
15	831500	Nut M 5	4	
19	2213002	Counter	1	(OPTION)*
20	833245	Emergency contactor	1	
21	833267	Inversing contactor	1	
22	833562	Selector contactor	1	
23	2248001	Transformer	1	
24	2248000	Rectifier	1	

(*)Option : The counter add only the times during lifting operation
The figures must be mutiplicated by 2.



2, BOULEVARD DE L'INDUSTRIE
B.P. 59 - 28501 VERNUILLET CEDEX
FRANCE

TEL. (33) 02 37 38 95 95

FAX. (33) 02 37 38 95 99

INTERNET : WWW.VERLINDE.COM

E-MAIL : CONTACT@VERLINDE.COM